

10 Gb/s BIDI SFP+ 80 km Transceiver



- Up to 11.3 Gb/s data links
- Up to 80 km transmission distance on SMF
- Metal enclosure
- Hot-pluggable SFP+ footprint
- Compliant with SFF 8431 and SFF 8472
- 10GBASE-BX
- 10G SONET/SDH, OTU2/2e
- RoHS Compliant

Ascent's SFPP-AT-LP-XXXX-80 transceivers are designed expressly for high-speed communication applications that require rates up to 11.3 Gb/s. They are designed to be compliant with the SFF-8472 SFP+ MSA. The module is suitable for data links up to 80 km in distance over a 9/125 μ m single mode fiber.

ASCENT SFP+ transceivers provide a unique enhanced digital diagnostic monitoring interface which allows real-time access to device operating parameters such as transceiver temperature, laser bias current, transmitted optical power, received optical power, and transceiver supply voltage. It also defines a sophisticated system of alarm and warning flags which alerts end users when particular operating parameters are outside of a factory set normal range.

Key Features

- Up to 11.3 Gbps Data Links
- Up to 80 km transmission on SMF
- Power dissipation < 1.0 W
- 1490 nm DFB laser and PIN receiver for SFPP-AT-LP-4955-80
- 1550 nm DFB laser and PIN receiver for SFPP-AT-LP-5549-80
- 2-wire interface with integrated Digital Diagnostic monitoring
- EEPROM with serial ID functionality
- Compliant with SFP+ MSA with LC connector
- Compliant with SFF 8431 and SFF 8472
- Single + 3.3V power supply
- Compatible with Juniper

Pin Assignment

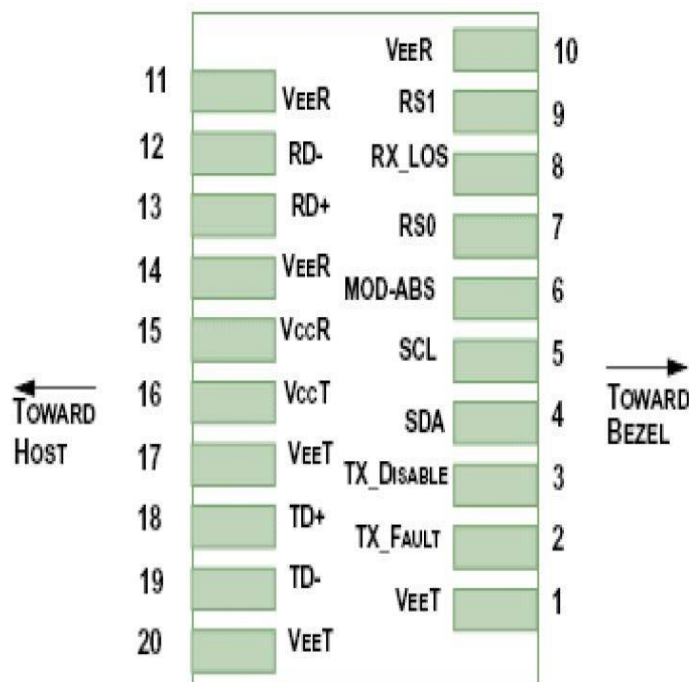

Diagram of Host Board Connector Block Pin Numbers and Name

Pin	Symbol	Name/Description	NOTE
1	V _{EE T}	Transmitter Ground (Common with Receiver Ground)	1

2	T _{FAULT}	Transmitter Fault.	2
3	T _{DIS}	Transmitter Disable. Laser output disabled on high or open.	3
4	SDA	2-wire Serial Interface Data Line	4
5	SCL	2-wire Serial Interface Clock Line	4
6	MOD_ABS	Module Absent. Grounded within the module	4
7	RS0	Rate Select 0	5
8	LOS	Loss of Signal indication. Logic 0 indicates normal operation.	6
9	RS1	No connection required	1
10	V _{EER}	Receiver Ground (Common with Transmitter Ground)	1
11	V _{EER}	Receiver Ground (Common with Transmitter Ground)	1
12	RD-	Receiver Inverted DATA out. AC Coupled	
13	RD+	Receiver Non-inverted DATA out. AC Coupled	
14	V _{EER}	Receiver Ground (Common with Transmitter Ground)	1
15	V _{CCR}	Receiver Power Supply	
16	V _{CCT}	Transmitter Power Supply	
17	V _{EET}	Transmitter Ground (Common with Receiver Ground)	1
18	TD+	Transmitter Non-Inverted DATA in. AC Coupled.	
19	TD-	Transmitter Inverted DATA in. AC Coupled.	
20	V _{EET}	Transmitter Ground (Common with Receiver Ground)	1

Notes:

1. Circuit ground is internally isolated from chassis ground.
2. T_{FAULT} is an open collector/drain output, which should be pulled up with a 4.7 kΩ to 10 kΩ resistor on the host board if intended for use. Pull up voltage should be between 2.0 V to V_{cc} + 0.3 V. A high output indicates a transmitter fault caused by either the TX bias current or the TX output power exceeding the preset alarm thresholds. A low output indicates normal operation. In the low state, the output is pulled to <0.8V.
3. Laser output disabled on T_{DIS} > 2.0 V or open, enabled on T_{DIS} < 0.8 V.
4. Should be pulled up with 4.7 kΩ to 10 kΩ host board to a voltage between 2.0 V and 3.6 V. MOD_ABS pulls line low to indicate module is plugged in.
5. Internally pulled down per SFF-8431 Rev 4.1.
6. LOS is an open collector output. It should be pulled up with 4.7 kΩ to 10 kΩ on the host board to a voltage between 2.0 V and 3.6 V. Logic 0 indicates normal operation; logic 1 indicates loss of signal.

Regulatory Compliance

Feature	Reference	Performance
Electrostatic Discharge (ESD)	IEC/EN 61000-4-2	Compatible with standards
Electromagnetic Interference (EMI)	FCC Part 15 Class B EN 55022 Class B (CISPR 22a)	Compatible with standards
Laser Eye Safety	FDA 21CFR 1040.10, 1040.11 IEC/EN 60825-1, 2	Class 1 laser product
Component Recognition	IEC/EN 60950, UL	Compatible with standards
RoHS	2002/95/EC	Compatible with standards
EMC	EN61000-3	Compatible with standards

Host - Transceiver Interface Block Diagram

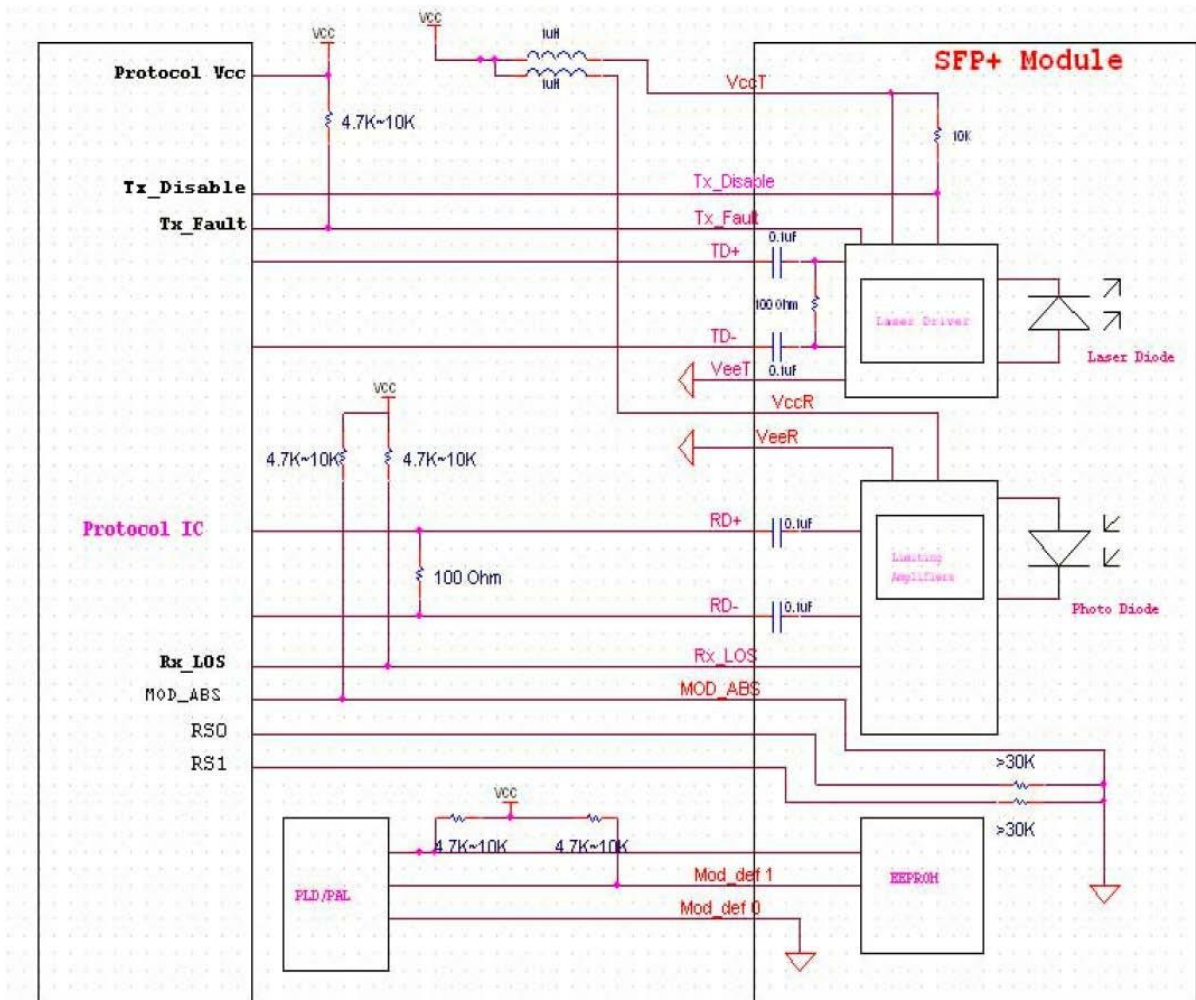

Outline Dimensions

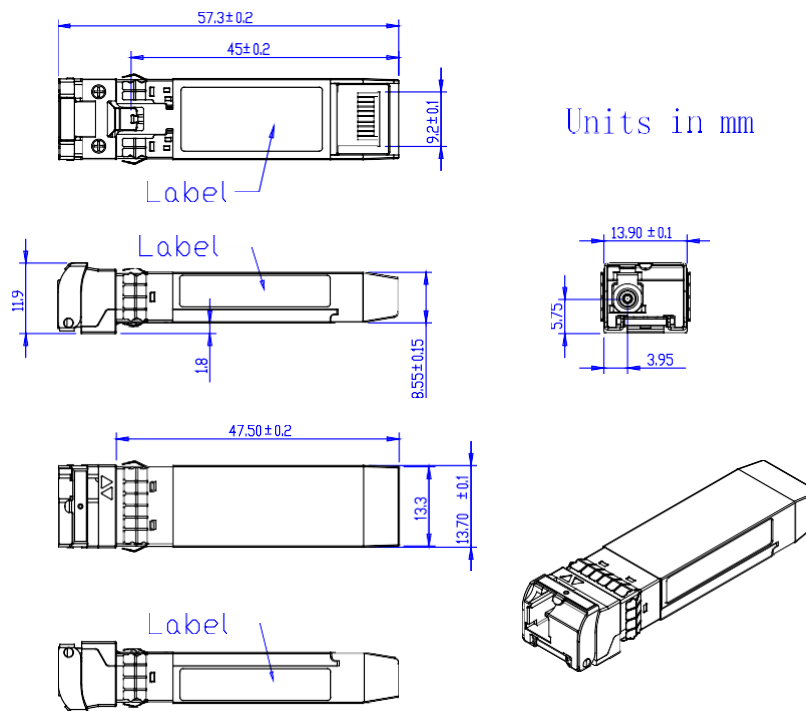

Digital Diagnostic Functions

ASCENT SFPP-AT-LP-XXXX-80 transceivers support the 2-wire serial communication protocol as defined in the SFP+ MSA.

The standard SFP serial ID provides access to identification information that describes the transceiver's capabilities, standard interfaces, manufacturer, and other information.

Additionally, ASCENT SFP+ transceivers provide a unique enhanced digital diagnostic monitoring interface which allows real-time access to device operating parameters such as transceiver temperature, laser bias current, transmitted optical power, received optical power, and transceiver supply voltage. It also defines a sophisticated system of alarm and warning flags which alerts end users when particular operating parameters are outside of a factory set normal range.

The SFP MSA defines a 256-byte memory map in EEPROM that is accessible over a 2-wire serial interface at the 8-bit address 1010000X (A0h). The digital diagnostic monitoring interface makes use of the 8-bit address 1010001X (A2h), so the originally defined serial ID memory map remains unchanged.

The operating and diagnostics information is monitored and reported by a Digital Diagnostics Transceiver Controller (DDTC) inside the transceiver, which is accessed through a 2-wire serial interface. When the serial protocol is activated, the serial clock signal (SCL, Mod Def 1) is generated by the host. The positive edge clocks data into the SFP transceiver into those

segments of the E2PROM that are not write-protected. The negative edge clocks data from the SFP transceiver. The serial data signal (SDA, Mod Def 2) is bi-directional for serial data transfer. The host uses SDA in conjunction with SCL to mark the start and end of serial protocol activation. The memories are organized as a series of 8-bit data words that can be addressed individually or sequentially.

Specifications

Absolute Maximum Ratings

Parameter	Symbol	Min.	Typ.	Max.	Unit	Notes
Storage Temperature	T _S	-40	-	85	°C	
Relative Humidity	RH	5	-	95	%	
Power Supply Voltage	V _{CC}	-0.3	-	4.0	V	
Signal Input Voltage		V _{CC} - 0.3	-	V _{CC} + 0.3	V	

Recommended Operating Conditions

Parameter	Symbol	Min.	Typ.	Max.	Unit	Notes
Case Operating Temperature	T _{CASE}	-10	-	70	°C	Commercial
	T _{CASE}	-40	-	85	°C	Industrial
Power Supply Voltage	V _{CC}	3.14	3.3	3.47	V	
Power Supply Current	I _{CC}	-	-	450	mA	
Data Rate	BR	-	10.3125	11.3	Gbps	
Transmission Distance	TD	-	-	80	km	
Coupled Fiber	Single-mode fiber					9/125 μm SMF

Optical Characteristics

Parameter	Symbol	Min.	Typ.	Max.	Unit	Notes
Transmitter						
Average Optical Power	P _{OUT}	0	-	4	dBm	SFPP-AT-LP-4955-80
		-1	-	3	dBm	SFPP-AT-LP-5549-80
Average Optical Power (Laser Off)	P _{OFF}	-	-	-30	dBm	1
Center Wavelength Range	λ _C	λ - 7.5	λ	λ + 7.5	nm	2
Side Mode Suppression Ratio	SMSR	30	-	-	dB	
Spectrum Bandwidth (-20 dB)	σ	-	-	0.3	nm	
Optical Extinction Ratio	ER	3.5	-	-	dB	3
Output Eye Mask	Compliant with IEEE 802.3ae					3
Receiver						
Input Optical Wavelength	λ _{IN}	1480	1490	1500	nm	SFPP-AT-LP-4955-80
		1540	1550	1560	nm	SFPP-AT-LP-5549-80
Receiver Sensitivity	P _{SEN}	-	-	-23	dBm	4
Input Saturation Power (Overload)	P _{SAT}	-6	-	-	dBm	4

LOS Assert	LOSA	-38	-	-	dBm
LOS De-assert	LOSD	-	-	-24	dBm
LOS Detect Hysteresis	P _{HYS}	0.5	-	8	dB

Notes:

1. The optical power is launched into an SMF
2. λ is the wavelength at room temperature
3. Measured with RPBS 2³¹-1 test pattern @10.3125Gbs
4. Measured with RPBS 2³¹-1 test pattern @10.3125Gbs BER $\leq 10^{-12}$

Electrical Characteristics

Parameter	Symbol	Min	Typ.	Max	Unit	Notes
Total Power Supply Current	I _{CC}	-	-	450	mA	Commercial
		-	-	500	mA	Industrial
Transmitter						
Differential Data Input Voltage	V _{DT}	180	-	1200	mVp-p	
Differential Line Input Impedance	R _{IN}	80	100	120	Ω	
Transmitter Fault Output-High	V _{FAULTH}	2.4	-	V _{CC}	V	
Transmitter Fault Output-Low	V _{FAULTL}	-0.3	-	0.8	V	
Transmitter Disable Voltage- High	V _{DISH}	2.0	-	V _{CC} +0.3	V	
Transmitter Disable Voltage- High	V _{DISL}	-0.3	-	0.8	V	
Receiver						
Differential Data Output Voltage	V _{DR}	300	-	850	mVp-p	
Differential line Output Impedance	R _{OUT}	80	100	120	Ω	
Receiver LOS Pull Up Resistor	R _{LOS}	4.7	-	10	k Ω	
Data Output Rise/Fall Time	tr/TF	24	-	-	ps	
LOS Fault	V _{LOSFAULT}	V _{CC} - 1.3	-	V _{CC} H _{OST}	V	
LOS Normal	V _{LOS_{NORM}}	V _{EE}	-	V _{EE} +0.8	V	

Ordering Information

Model	Description
SFPP-AT-LP-4955-80	SFP+ Plug-in, 10 Gbps, 80 km, TX=1490/RX=1550, single-mode fiber, LC/PC Blue
SFPP-AT-LP-5549-80	SFP+ Plug-in, 10 Gbps, 80 km, TX=1550/RX=1490, single-mode fiber, LC/PC Blue
JSPP-AT-LP-4955-80	SFP+ Plug-in, 10 Gbps, 80 km, TX=1490/RX=1550, single-mode fiber, LC/PC Blue
JSPP-AT-LP-5549-80	SFP+ Plug-in, 10 Gbps, 80 km, TX=1550/RX=1490, single-mode fiber, LC/PC Blue
JSPP-AT-LP-4955-80A	SFP+ Plug-in, 10 Gbps, 80 km, TX=1490/RX=1550, single-mode fiber, LC/PC Blue, industrial temp
JSPP-AT-LP-5549-80A	SFP+ Plug-in, 10 Gbps, 80 km, TX=1550/RX=1490, single-mode fiber, LC/PC Blue, industrial temp

Contact Information



Ascent Communication Technology Ltd

AUSTRALIA

961 Mountain Highway, Boronia
Victoria 3155, AUSTRALIA
Phone: +61-488 293 682

HONG KONG SAR

Unit 9, 12th Floor, Wing Tuck Commercial Centre
177 Wing Lok Street, Sheung Wan, HONG KONG
Phone: +852-2851 4722

CHINA

Unit 1907, 600 Luban Road
200023, Shanghai CHINA
Phone: +86-21-60232616

USA

2710 Thomes Ave, Cheyenne
WY 82001, USA
Phone: +1-203 816 5188

EUROPE

Pfarrer-Bensheimer-Strasse 7a
55129 Mainz, GERMANY
Phone: +49 (0) 6136 926 3246

VIETNAM

15 /F TTC Building, Duy Tan Street, Cau Giay Dist.
Hanoi, VIETNAM
Phone: +84 168 481 8348

WEB: www.ascentcomtec.com **EMAIL:** sales@ascentcomtec.com

Specifications and product availability are subject to change without notice.

Copyright © 2016 Ascent Communication Technology Limited. All rights reserved.

Ver. ACT_SFPP-AT-LP-XXXX-80_Datasheet_V1b_Mar_2016