

## 40G QSFP+ to 4x10G SFP+ Active Optical Cable

---

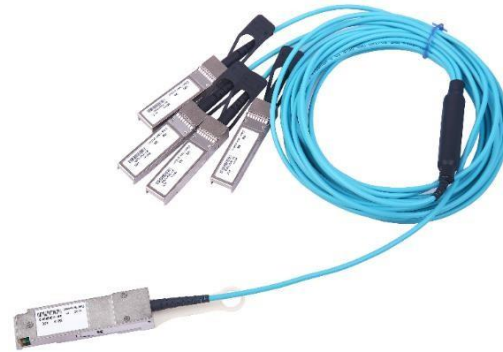

- **40G to 10G Ethernet Interoperability**
- **Aggregate 4 SFP+ 10G Into Single QSFP+ 40G Interface**
- **150m links on OM4 multimode fiber**
- **Electrically hot-pluggable**
- **QSFP+ module compliant to SFF 8436 MSA**
- **SFP+ module compliant to SFF 8431 MSA**
- **RoHS Compliant**

ASCENT 40G QSFP+ to 4x10G SFP+ Active Optical breakout Cable can be used to convert a 40 G QSFP+ input into 4 × 10 G SFP+ outputs for high-speed storage and data applications.

This optical breakout cables are suitable for very short distances and offer a flexible way to connect within racks and across adjacent racks. Active optical cables are much thinner and lighter than copper cables, which makes cabling easier. It also enables efficient system airflow and have no electromagnetic interference (EMI) issues, which is critical in high-density racks. These breakout cables connect to a 40G QSFP port of Ascent 40G switch on one end and to four 10G SFP+ ports of an Ascent switch on the other end.

Compliant with SFF 8436 MSA and SFF 8431 MSA standards, these active optical cables offer a low-cost solution for data centers and high-performance computing

## Key Features

- Supports 40G to 10G Ethernet interoperability
- Aggregate 4 discrete SFP+ 10G channels into single parallel QSFP+ 40G interface
- Maximum link length of 100m links on OM3 multimode fiber Or 150m links on OM4 multimode fiber
- Electrically hot-pluggable
- Electrical interface compliant to QSFP+ connector
- (SFF-8436) and SFP+ connectors (SFF-8431)
- Case operating temperature range: 0°C to 70°C

## Outline Dimensions

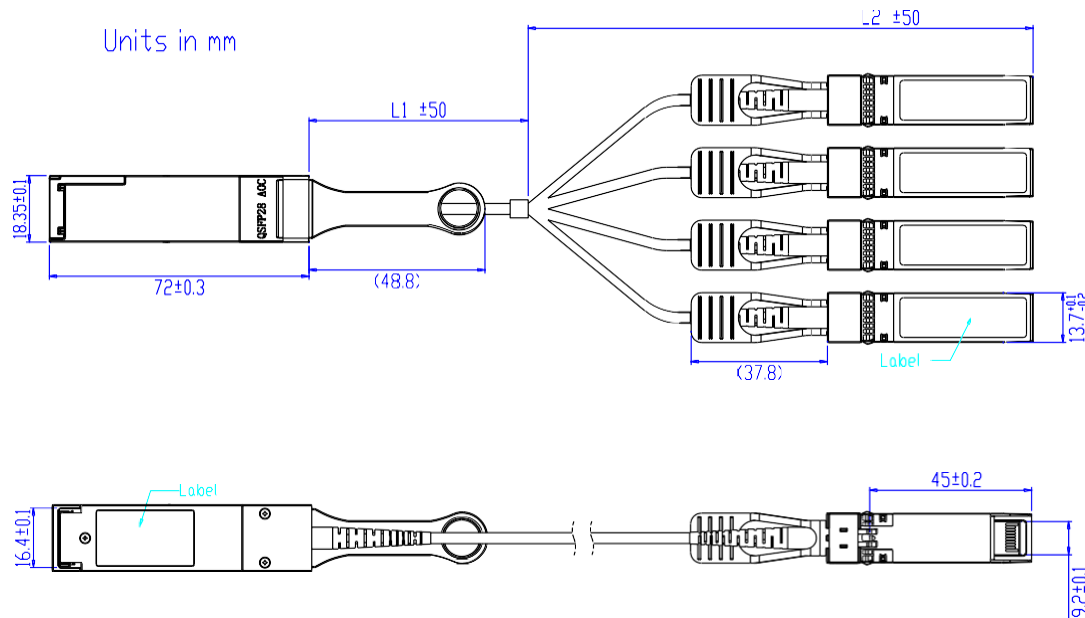
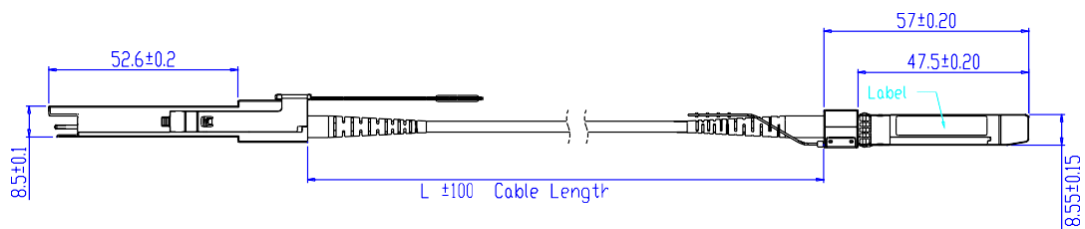

## Pin Assignment

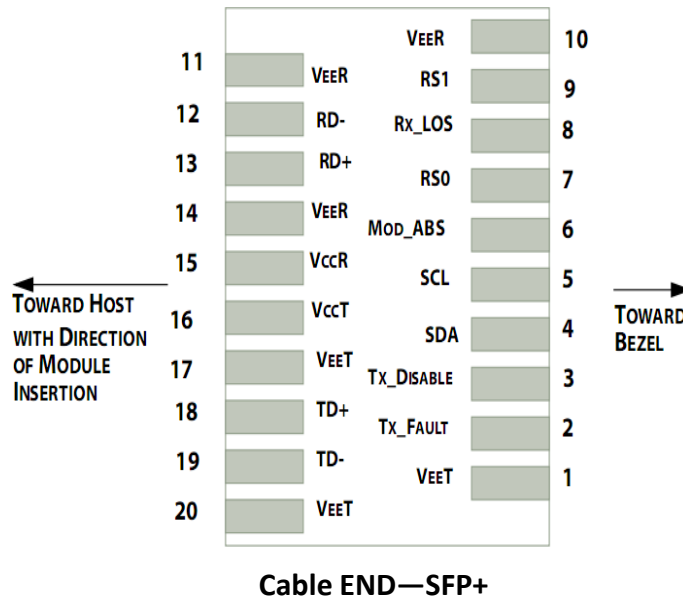

Pin	Symbol	Name/Description	NOTE
1	$V_{EET}$	Transmitter Ground (Common with Receiver Ground)	1
2	$T_{FAULT}$	Transmitter Fault.	2
3	$T_{DIS}$	Transmitter Disable. Laser output disabled on high or open.	3
4	SDA	2-wire Serial Interface Data Line	4
5	SCL	2-wire Serial Interface Clock Line	4
6	MOD_ABS	Module Absent. Grounded within the module	4
7	RS0	Rate Select 0	5
8	LOS	Loss of Signal indication. Logic 0 indicates normal operation.	6
9	RS1	No connection required	1
10	$V_{EER}$	Receiver Ground (Common with Transmitter Ground)	1
11	$V_{EER}$	Receiver Ground (Common with Transmitter Ground)	1
12	RD-	Receiver Inverted DATA out. AC Coupled	
13	RD+	Receiver Non-inverted DATA out. AC Coupled	
14	$V_{EER}$	Receiver Ground (Common with Transmitter Ground)	1
15	$V_{CCR}$	Receiver Power Supply	
16	$V_{CCT}$	Transmitter Power Supply	
17	$V_{EET}$	Transmitter Ground (Common with Receiver Ground)	1
18	TD+	Transmitter Non-Inverted DATA in. AC Coupled.	
19	TD-	Transmitter Inverted DATA in. AC Coupled.	
20	$V_{EET}$	Transmitter Ground (Common with Receiver Ground)	1

**Notes:**

1. Circuit ground is internally isolated from chassis ground.
2.  $T_{FAULT}$  is an open collector/drain output, which should be pulled up with a 4.7k – 10k Ohms resistor on the host board if intended for use. Pull up voltage should be between 2.0V to  $V_{cc} + 0.3V$ . A high output indicates

a transmitter fault caused by either the TX bias current or the TX output power exceeding the preset alarm thresholds. A low output indicates normal operation. In the low state, the output is pulled to <0.8V.

1. Laser output disabled on  $T_{DIS} > 2.0V$  or open, enabled on  $T_{DIS} < 0.8V$ .
2. Should be pulled up with 4.7kΩ- 10kΩ host board to a voltage between 2.0V and 3.6V. MOD\_ABS pulls line low to indicate module is plugged in.
3. Internally pulled down per SFF-8431 Rev 4.1.
4. LOS is open collector output. It should be pulled up with 4.7kΩ – 10kΩ on host board to a voltage between 2.0V and 3.6V. Logic 0 indicates normal operation; logic 1 indicates loss of signal.

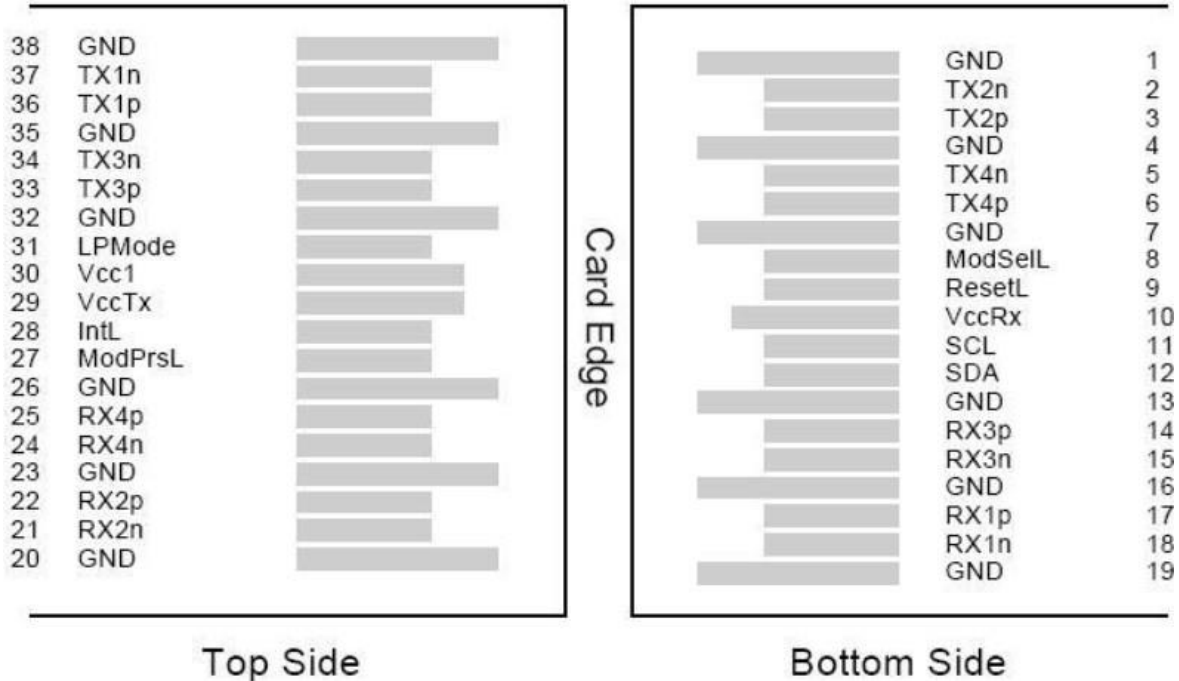

### Cable END—QSFP+

Pin	Symbol	Name/Description	NOTE
1	GND	Transmitter Ground (Common with Receiver Ground)	1
2	Tx2n	Transmitter Inverted Data Input	
3	Tx2p	Transmitter Non-Inverted Data output	
4	GND	Transmitter Ground (Common with Receiver Ground)	1
5	Tx4n	Transmitter Inverted Data Input	
6	Tx4p	Transmitter Non-Inverted Data output	
7	GND	Transmitter Ground (Common with Receiver Ground)	1
8	ModSelL	Module Select	
9	ResetL	Module Reset	
10	VccRx	3.3V Power Supply Receiver	2
11	SCL	2-Wire serial Interface Clock	
12	SDA	2-Wire serial Interface Data	
13	GND	Transmitter Ground (Common with Receiver Ground)	
14	Rx3p	Receiver Non-Inverted Data Output	
15	Rx3n	Receiver Inverted Data Output	
16	GND	Transmitter Ground (Common with Receiver Ground)	1
17	Rx1p	Receiver Non-Inverted Data Output	

18	Rx1n	Receiver Inverted Data Output	
19	GND	Transmitter Ground (Common with Receiver Ground)	1
20	GND	Transmitter Ground (Common with Receiver Ground)	1
21	Rx2n	Receiver Inverted Data Output	
22	Rx2p	Receiver Non-Inverted Data Output	
23	GND	Transmitter Ground (Common with Receiver Ground)	1
24	Rx4n	Receiver Inverted Data Output	1
25	Rx4p	Receiver Non-Inverted Data Output	
26	GND	Transmitter Ground (Common with Receiver Ground)	1
27	ModPrsl	Module Present	
28	IntL	Interrupt	
29	VccTx	3.3V power supply transmitter	2
30	Vcc1	3.3V power supply	2
31	LPMODE	Low Power Mode, not connect	
32	GND	Transmitter Ground (Common with Receiver Ground)	1
33	Tx3p	Transmitter Non-Inverted Data Input	
34	Tx3n	Transmitter Inverted Data Output	
35	GND	Transmitter Ground (Common with Receiver Ground)	1
36	Tx1p	Transmitter Non-Inverted Data Input	
37	Tx1n	Transmitter Inverted Data Output	
38	GND	Transmitter Ground (Common with Receiver Ground)	1

**Notes:**

1. GND is the symbol for signal and supply (power) common for QSFP+ modules. All are common within the QSFP+ module and all module voltages are referenced to this potential unless otherwise noted. Connect these directly to the host board signal common ground plane.
2. VccRx, Vcc1 and VccTx are the receiving and transmission power suppliers and shall be applied concurrently. Recommended host board power supply filtering is shown below. Vcc Rx, Vcc1 and Vcc Tx may be internally connected within the QSFP+ transceiver module in any combination. The connector pins are each rated for a maximum current of 500mA.

## Host – Transceiver Interface Block Diagram

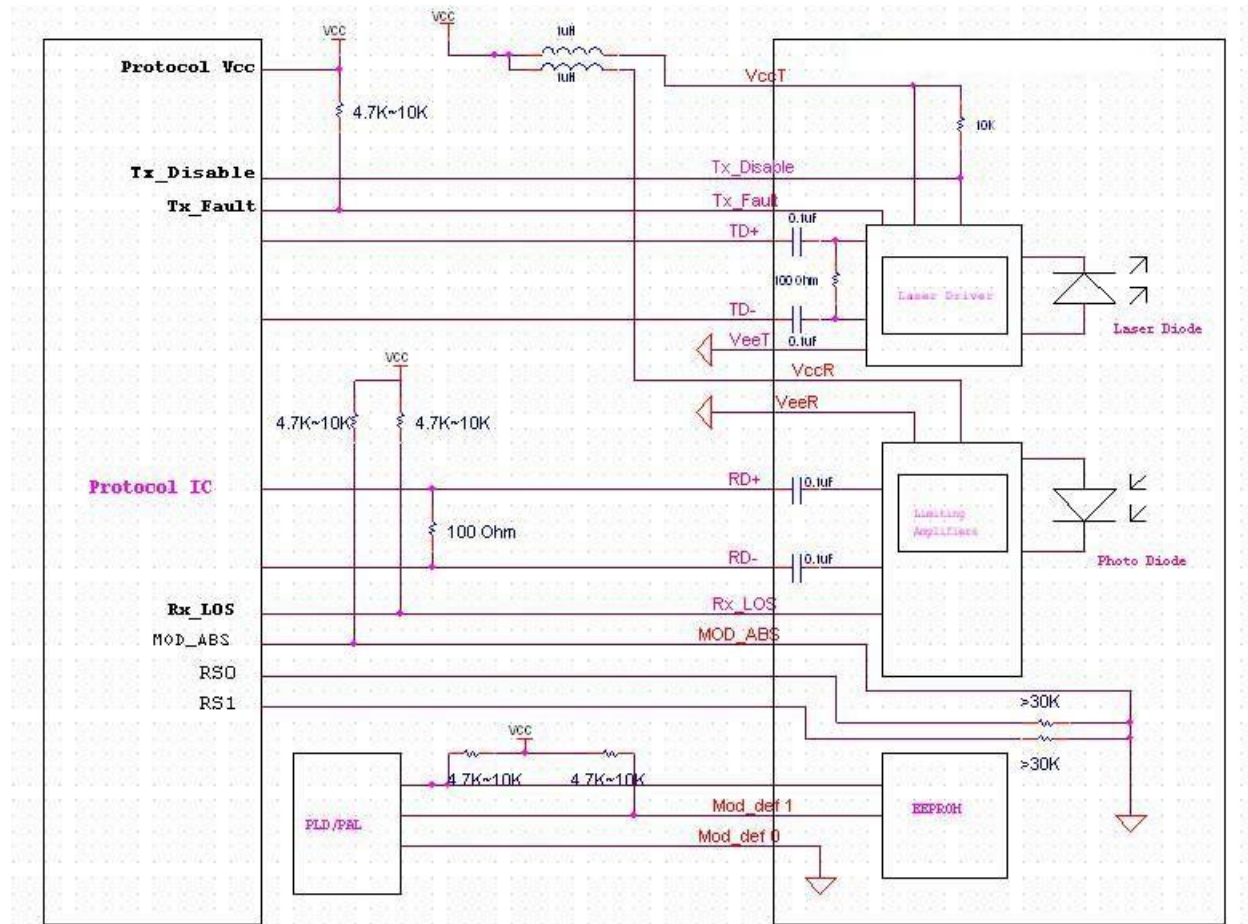

Cable END—SFP+

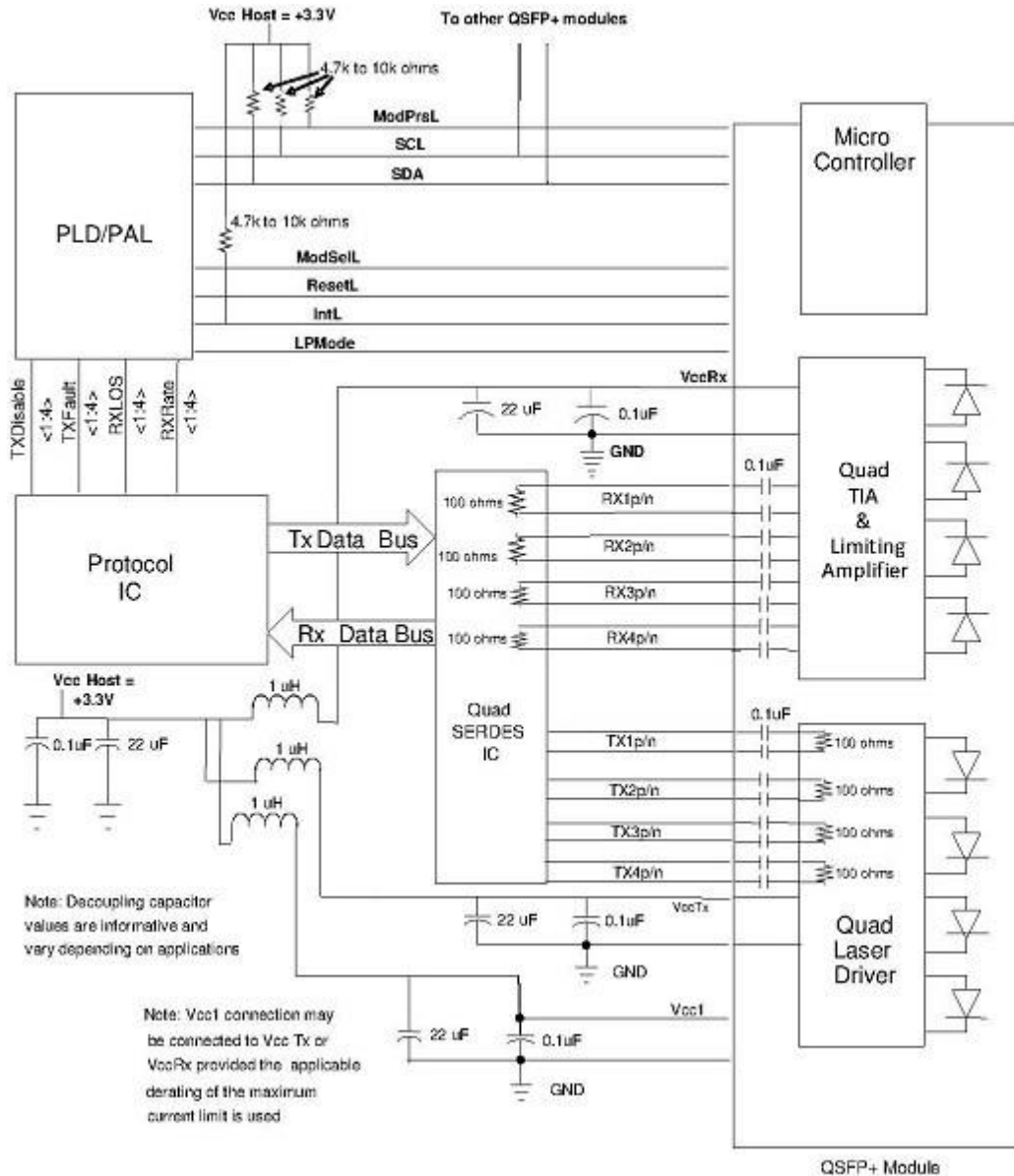

Cable END—QSFP+

## Specifications

### Absolute Maximum Ratings

Parameter	Symbol	Value	Notes
Storage Temperature	Ts	-40 °C to 85 °C	
Relative Humidity	RH	5 % to 95 %	
Power Supply Voltage	Vcc	-0.3 V to 4.0 V	
Signal Input Voltage		Vcc -0.3 V to Vcc + 0.3 V	

### Recommended Operating Conditions

Parameter	Symbol	Value	Notes
Case Operating Temperature	Tcase	0 °C to 70°C	Without air flow
Power Supply Voltage	Vcc	3.13 V to 3.46 V, 3.3 V typical	
Power Supply Current	Icc	300 mA maximum 450 mA maximum	Per cable end- SFP+ Per cable end- QSFP+
Data Rate	BR	10.3125 Gbps 41.25 Gbps	SFP+ bit rate QSFP+ aggregate bit rate

## Ordering Information

Item	Description
QSFP-AQ-AOC-4G-03	40G QSFP+ to 4x10G SFP+ Active Optical Breakout Cable 3 m
QSFP-AQ-AOC-4G-05	40G QSFP+ to 4x10G SFP+ Active Optical Breakout Cable 5m
QSFP-AQ-AOC-4G-10	40G QSFP+ to 4x10G SFP+ Active Optical Breakout Cable 10 m
QSFP-AQ-AOC-4G-50	40G QSFP+ to 4x10G SFP+ Active Optical Breakout Cable 50 m

### Notes:

1. Cable length's range of SFP+ end to 1- 4 point must be 0.5 to 3 m.
2. More detail product selection and cable lengths, please contact Ascent sales representative.



## Contact Information

---

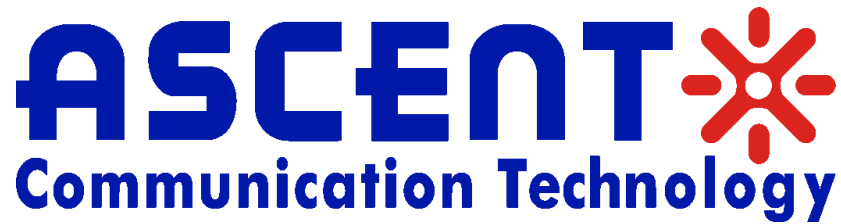

### Ascent Communication Technology Ltd

#### AUSTRALIA

140 William Street, Melbourne  
Victoria 3000, AUSTRALIA  
Phone: +61-3-8691 2902

#### CHINA

Unit 1933, 600 Luban Road  
200023, Shanghai, CHINA  
Phone: +86-21-60232616

#### EUROPE

Pfarrer-Bensheimer-Strasse 7a  
55129 Mainz, GERMANY  
Phone: +49 (0) 6136 926 3246

#### Hong Kong SAR

Unit 9, 12<sup>th</sup> Floor, Wing Tuck Commercial Centre  
177 Wing Lok Street, Sheung Wan, Hong Kong SAR  
Phone: +852-2851 4722

#### USA

2710 Thomes Ave  
Cheyenne, WY 82001, USA  
Phone: + 1 203 350 9822

#### VIETNAM

11th Floor, Hoa Binh Office Tower  
106 Hoang Quoc Viet Street, Nghia Do Ward  
Cau Giay District, Hanoi 10649, VIETNAM  
Phone: +84-24-37955917

**WEB:** [www.ascentcomtec.com](http://www.ascentcomtec.com)

**EMAIL:** [sales@ascentcomtec.com](mailto:sales@ascentcomtec.com)

Specifications and product availability are subject to change without notice.  
Copyright © 2024 Ascent Communication Technology Limited. All rights reserved.  
Ver. ACT\_QSFP-AQ-AOC-4G\_Datasheet\_V1d\_Apr\_2018