

100 Gb/s QSFP28 Passive Direct Attach Copper Twinax Cable

QSFP28 Series



- **100 Gigabit Ethernet**
- **Fiber Channel over Ethernet**
- **InfiniBand EDR**
- **Data storage and communication industry Switch / router / HBA**
- **Enterprise network SAN**
- **Data Center Network**

Ascent's QSFP28 passive direct attach copper twinax cable assemblies are high-performance, cost-effective I/O solutions for 100G Ethernet and 100G Fiber Channel applications.

QSFP28 copper modules could achieve high port density, configurability and utilization at a very low cost and reduced power budget. The high-speed cable assemblies meet and exceed Gigabit Ethernet and Fiber Channel industry standard requirements for performance and reliability.

These assemblies are called "passive" copper cables because there isn't any signal conditioning circuitry (e.g. crosstalk or echo cancellation) contained within the SFP+ connector. Sometimes these assemblies are referred to as "DAC" or "Direct Attached Copper" cables. Inside the SFP+ MSA footprint optical cables can be used that require optical transceivers or Active Optical Cables (AOC) that contain the transceiver as part of the cable.

Key Features

- QSFP28 conforms to Small Form-Factor SFF8665
- 4-channel full-duplex passive copper cable transceiver
- Supports data rates: 25.78 Gb/s (per channel)
- Maximum aggregate data rate: 100Gb/s (4 x 25.78Gb/s)
- IEEE 802.3bj 100GEBASE-CR4
- Copper link x (x=1m, 2m, 3m, 5m)
- Power Supply: +3.3V
- Low crosstalk
- I2C based two-wire serial interface for EEPROM signature which can be customized
- Operating temperature: 0 °C to +70 °C
- Compatible to QSFP28 MSA
- RoHS Compliant

Outline Dimensions

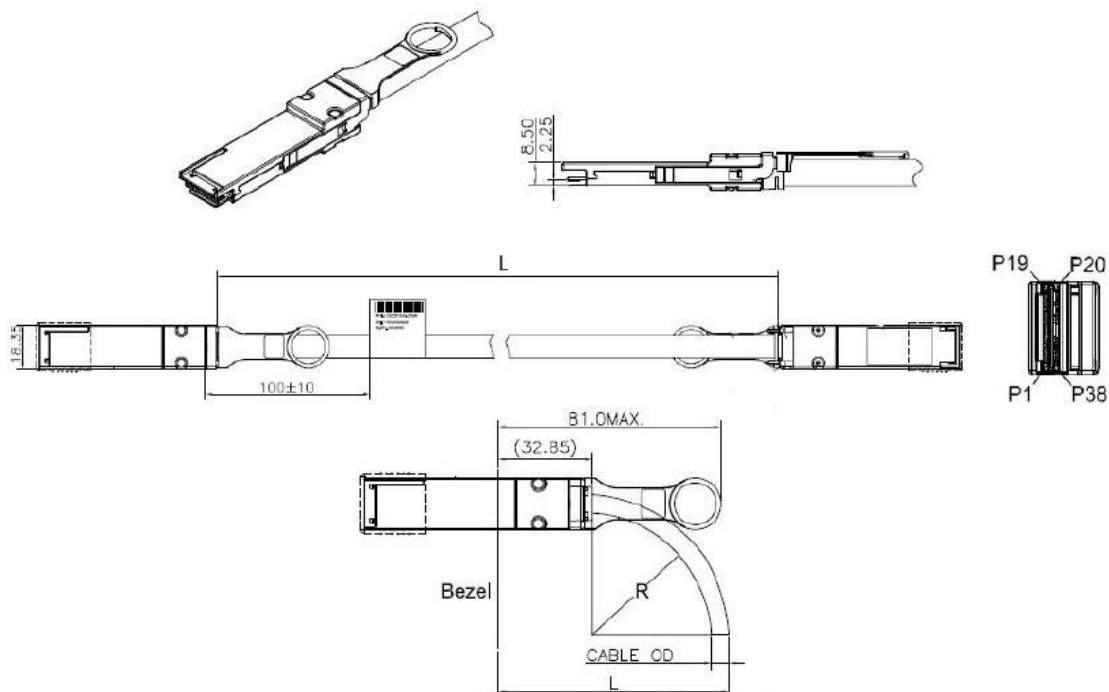

Cable Gauge	Cable "OD"	Minimum Bend Radius "R"	Minimum Bend Space "L"
30 AWG	6.6 mm	33 mm	72.45 mm
26 AWG	8.4 mm	42 mm	83.25 mm

Pin Assignment

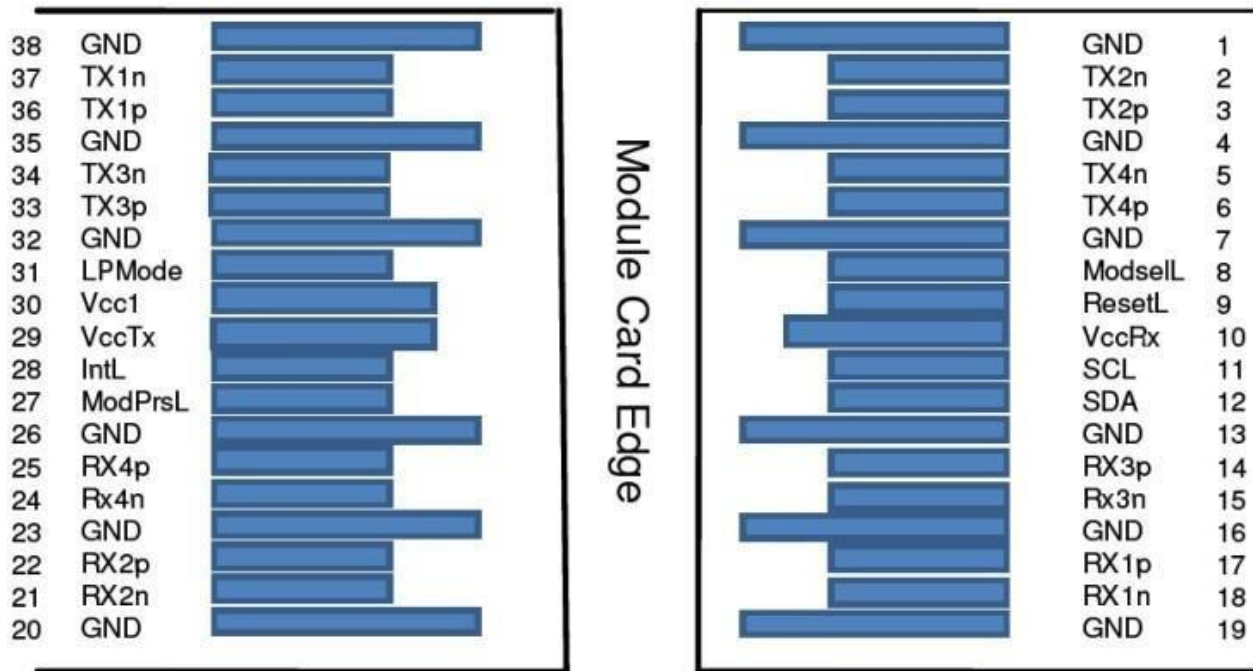

Top Side
Viewed From Top

Bottom Side
Viewed From Bottom

Pin out of Connector Block on Host Board

Pin	Logic	Symbol	Name/Description	Note
1		GND	Ground	1
2	CML-I	Tx2n	Transmitter Inverted Data	
3	CML-I	Tx2p	Transmitter Non-Inverted	
4		GND	Ground	1
5	CML-I	Tx4n	Transmitter Inverted Data	
6	CML-I	Tx4p	Transmitter Non-Inverted	
7		GND	Ground	1
8	LVTTL-I	ModSel	Module Select	
9	LVTTL-I	ResetL	Module Reset	
10		Vcc Rx	+3.3V Power Supply	2
11	LVC MOS	SCL	2-wire serial interface	
12	LVC MOS	SDA	2-wire serial interface	
13		GND	Ground	1
14	CML-O	Rx3p	Receiver Non-Inverted	
15	CML-O	Rx3n	Receiver Inverted Data	
16		GND	Ground	1

17	CML-O	Rx1p	Receiver Non-Inverted	
18	CML-O	Rx1n	Receiver Inverted Data	
19		GND	Ground	1
20		GND	Ground	1
21	CML-O	Rx2n	Receiver Inverted Data	
22	CML-O	Rx2p	Receiver Non-Inverted	
23		GND	Ground	1
24	CML-O	Rx4n	Receiver Inverted Data	
25	CML-O	Rx4p	Receiver Non-Inverted	
26		GND	Ground	1
27	LVTTTL-O	ModPrs	Module Present	
28	LVTTTL-O	IntL	Interrupt	
29		Vcc Tx	+3.3V Power supply	2
30		Vcc1	+3.3V Power supply	2
31	LVTTTL-I	LPMODE	Low Power Mode	
32		GND	Ground	1
33	CML-I	Tx3p	Transmitter Non-Inverted	
34	CML-I	Tx3n	Transmitter Inverted Data	
35		GND	Ground	1
36	CML-I	Tx1p	Transmitter Non-Inverted	
37	CML-I	Tx1n	Transmitter Inverted Data	
38		GND	Ground	1

Notes:

1. GND is the symbol for signal and supply (power) common for the QSFP+ module. All are common within the QSFP+ module and all module voltages are referenced to this potential unless otherwise noted. Connect these directly to the hostboard signal-common ground plane.

2. Vcc Rx, Vcc1 and Vcc Tx are the receiver and transmitter power supplies and shall be applied concurrently. Requirements defined for the host side of the Host Edge Card Connector are listed in Table 6. Recommended host board power supply filtering is shown in Figure 4. Vcc Rx Vcc1 and Vcc Tx may be internally connected within the QSFP+ Module module in any combination. The connector pins are each rated for a maximum current of 500 mA.

Channel Insertion Loss Budget

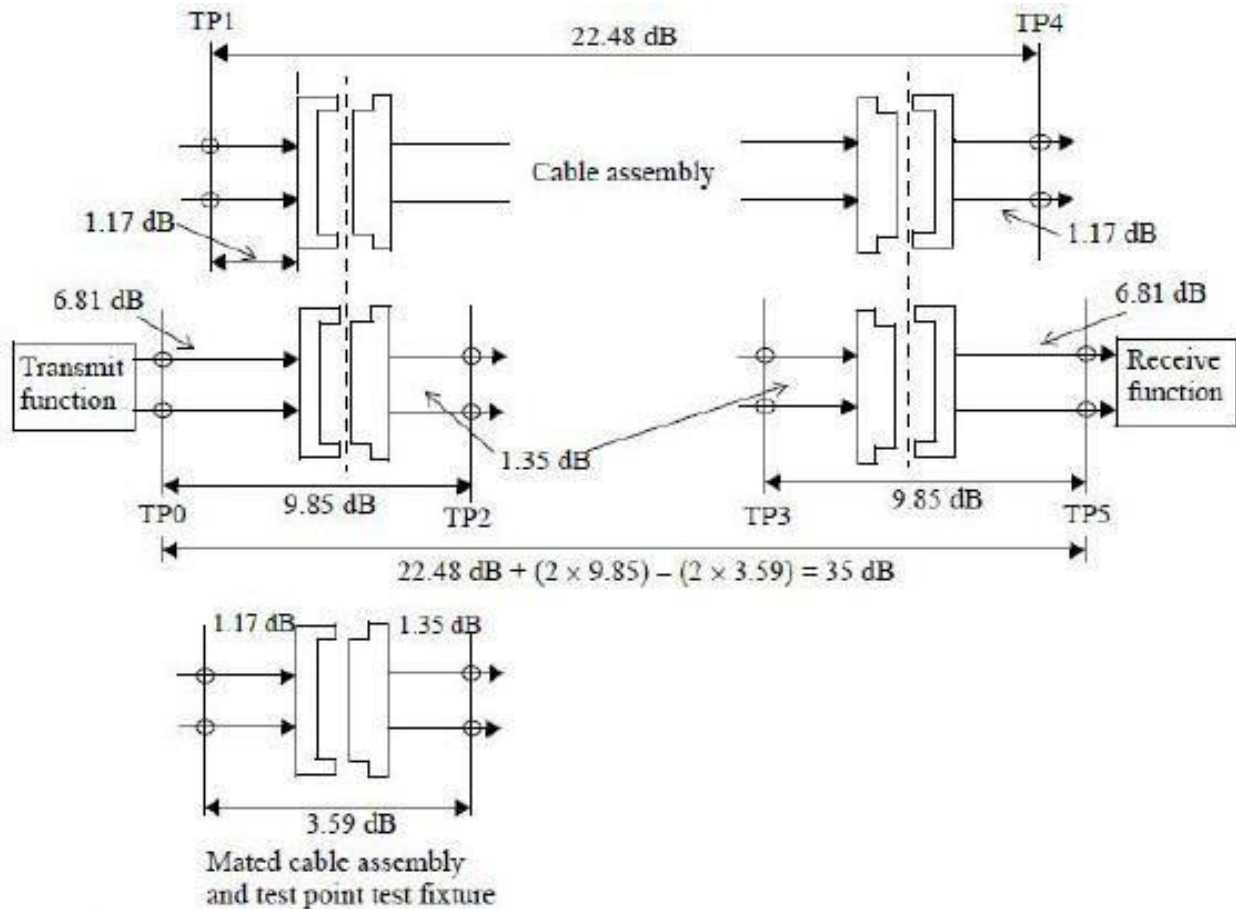

35 dB Channel insertion loss budget at 12.8906 GHz

Note: The connector insertion loss is 1.07 dB for the mated test fixture. The host connector is allocated 0.62dB of additional margin.

Specifications

Absolute Maximum Ratings

Parameter	Symbol	Min.	Typ.	Max.	Unit
Storage Temperature		-40		+85	°C
Operating Case Temperature	Tc	0		+70	°C
Power Supply Voltage	VCC3	3.14	3.3	3.47	V
Data Rate Per Lane		1		25.78	Gb/s

Note: Damage may occur if the transceiver is subjected to conditions beyond the limits.

High Speed Characteristics

Parameter	Symbol	Min.	Typ.	Max.	Unit	Note
Differential Impedance	RIN, P	9	100	110	Ω	
Insertion Loss	SDD2	8		22.48	dB	At 12.8906
Differential Return Loss	SDD11	12.45		See 1	dB	At 0.05 to
	SDD22	3.12		See 2		At 4.1 to 19
Common-Mode to Common-Mode Output Return Loss	SCC11	2			dB	At 0.2 to 19 GHz
	SCC22					
Differential to Common-Mode Return Loss	SCD11	12		See 3	dB	At 0.01 to
Differential to Common Mode Conversion Loss	SCD22	10.58		See 4		At 12.89 to
	SCD21-IL	10			dB	At 0.01 to
Channel Operating Margin	COM			See 5		At 12.89 to
		6.3				At 15.7 to
		3			dB	

Notes:

1. Reflection Coefficient given by equation $SDD11(dB) < 16.5 - 2 \times \sqrt{f}$, with f in GHz.
2. Reflection Coefficient given by equation $SDD11(dB) < 10.66 - 14 \times \log_{10}(f/5.5)$, with f in GHz.
3. Reflection Coefficient given by equation $SCD11(dB) < 22 - (20/25.78) \times f$, with f in GHz.
4. Reflection Coefficient given by equation $SCD11(dB) < 15 - (6/25.78) \times f$, with f in GHz.
5. Reflection Coefficient given by equation $SCD21(dB) < 27 - (29/22) \times f$, with f in GHz.

Ordering Information

Product Name	Product Description
QSFP-100DAC-001	100G QSFP28 Passive Direct Attach Copper Twinax Cable, 1 m, 30 AWG
QSFP-100DAC-002	100G QSFP28 Passive Direct Attach Copper Twinax Cable, 2 m, 30 AWG
QSFP-100DAC-003	100G QSFP28 Passive Direct Attach Copper Twinax Cable, 3 m, 28 AWG
QSFP-100DAC-004	100G QSFP28 Passive Direct Attach Copper Twinax Cable, 4 m, 28 AWG
QSFP-100DAC-005	100G QSFP28 Passive Direct Attach Copper Twinax Cable, 5 m, 26 AWG
JQ-100DAC-003	100G QSFP28 Passive Direct Attach Copper Twinax Cable, 3 m, 28 AWG, Compatible with Juniper

Contact Information



Ascent Communication Technology Ltd

AUSTRALIA

140 William Street, Melbourne
Victoria 3000, AUSTRALIA
Phone: +61-3-8691 2902

CHINA

Unit 1933, 600 Luban Road
200023, Shanghai, CHINA
Phone: +86-21-60232616

EUROPE

Pfarrer-Bensheimer-Strasse 7a
55129 Mainz, GERMANY
Phone: +49 (0) 6136 926 3246

Hong Kong SAR

Unit 9, 12th Floor, Wing Tuck Commercial Centre
177 Wing Lok Street, Sheung Wan, Hong Kong SAR
Phone: +852-2851 4722

USA

2710 Thomes Ave
Cheyenne, WY 82001, USA
Phone: + 1 203 350 9822

VIETNAM

11th Floor, Hoa Binh Office Tower
106 Hoang Quoc Viet Street, Nghia Do Ward
Cau Giay District, Hanoi 10649, VIETNAM
Phone: +84-24-37955917

Specifications and product availability are subject to change without notice.
Copyright © 2024 Ascent Communication Technology Limited. All rights reserved.
Ver. ACT_QSFP-100DAC_Cable_Datasheet_V1e_Aug_2020