

1.25 Gb/s 1310 nm Single-Mode SFP Transceiver

SFP Series

- Up to 1.25 Gb/s data links
- 1310 nm FP laser transmitter and PIN photo-detector
- Up to 10(20) km on 9/125 μ m SMF
- Hot-pluggable SFP footprint
- Duplex LC/UPC
- Low power dissipation
- RoHS compliant and lead-free
- Single +3.3 V power supply
- Supports Digital Diagnostic Monitoring interface
- Compliant with SFF-8472
- Compliant with IEEE802.3z



ASCENT's SFP-AG-LP-31-10 Small Form Factor Pluggable (SFP) transceivers are compatible with the Small Form Factor Pluggable Multi-Sourcing Agreement (MSA). The transceiver consists of five sections: the LD driver, the limiting amplifier, the digital diagnostic monitor, the 1310nm FP laser and the PIN/TIA. The module data link up to 20 km in 9/125 μ m Single-mode fiber.

This transceiver meets the Small Form Pluggable (SFP) industry standard package utilizing an integral LC-Duplex optical interface connector. An enhanced Digital Diagnostic Monitoring Interface compliant with SFF-8472 has been incorporated into the transceiver. It allows real time access to the transceiver operating parameters such as transceiver temperature, laser bias current, transmitted optical power, and received optical power and transceiver supply voltage by reading a built-in memory with I2C interface.

The optical output can be disabled by a LVTTTL logic high-level input of Tx Disable, and the system also can disable the module via I2C. Tx Fault is provided to indicate that degradation of the laser. Loss of Signal (LOS) output is provided to indicate the loss of an input optical signal of receiver or the link status with partner. The system can also get the LOS (or Link)/Disable/Fault information via I2C register access.

Key Features

- Up to 1.25 Gb/s data links
- FP laser transmitter and PIN photo-detector
- Up to 10(20) km on 9/125 μ m SMF
- Hot-pluggable SFP footprint
- Duplex LC/UPC type pluggable optical interface
- Low power dissipation
- Metal enclosure, for lower EMI
- RoHS compliant and lead-free
- Single +3.3 V power supply
- Supports Digital Diagnostic Monitoring interface
- Compliant with SFF-8472 and IEEE802.3z
- Switch to Switch Interface
- Gigabit Ethernet
- Switched Backplane Applications
- Router/Server Interface
- Other Optical Links

Outline Diagram

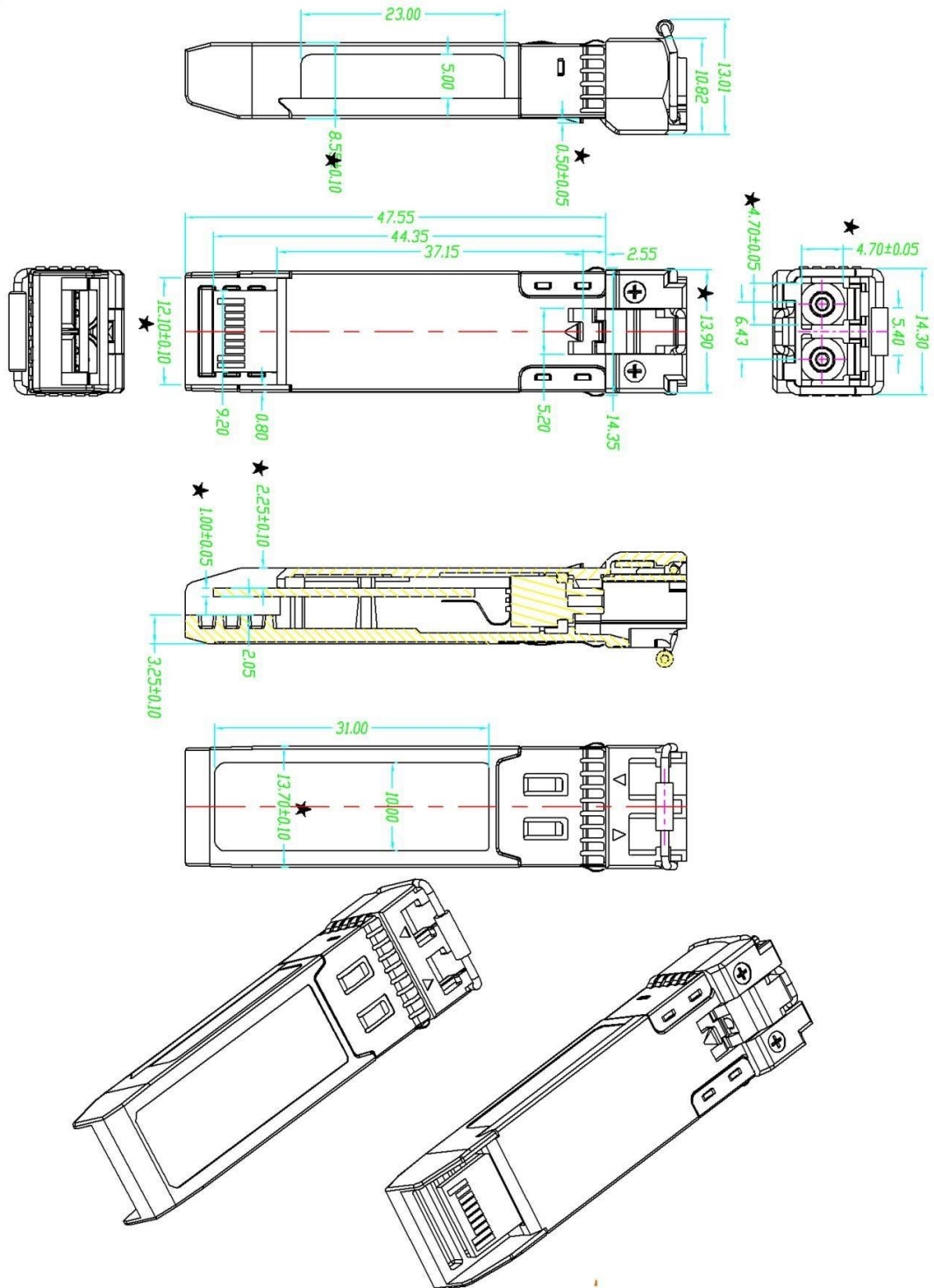

Recommend Circuit Schematic

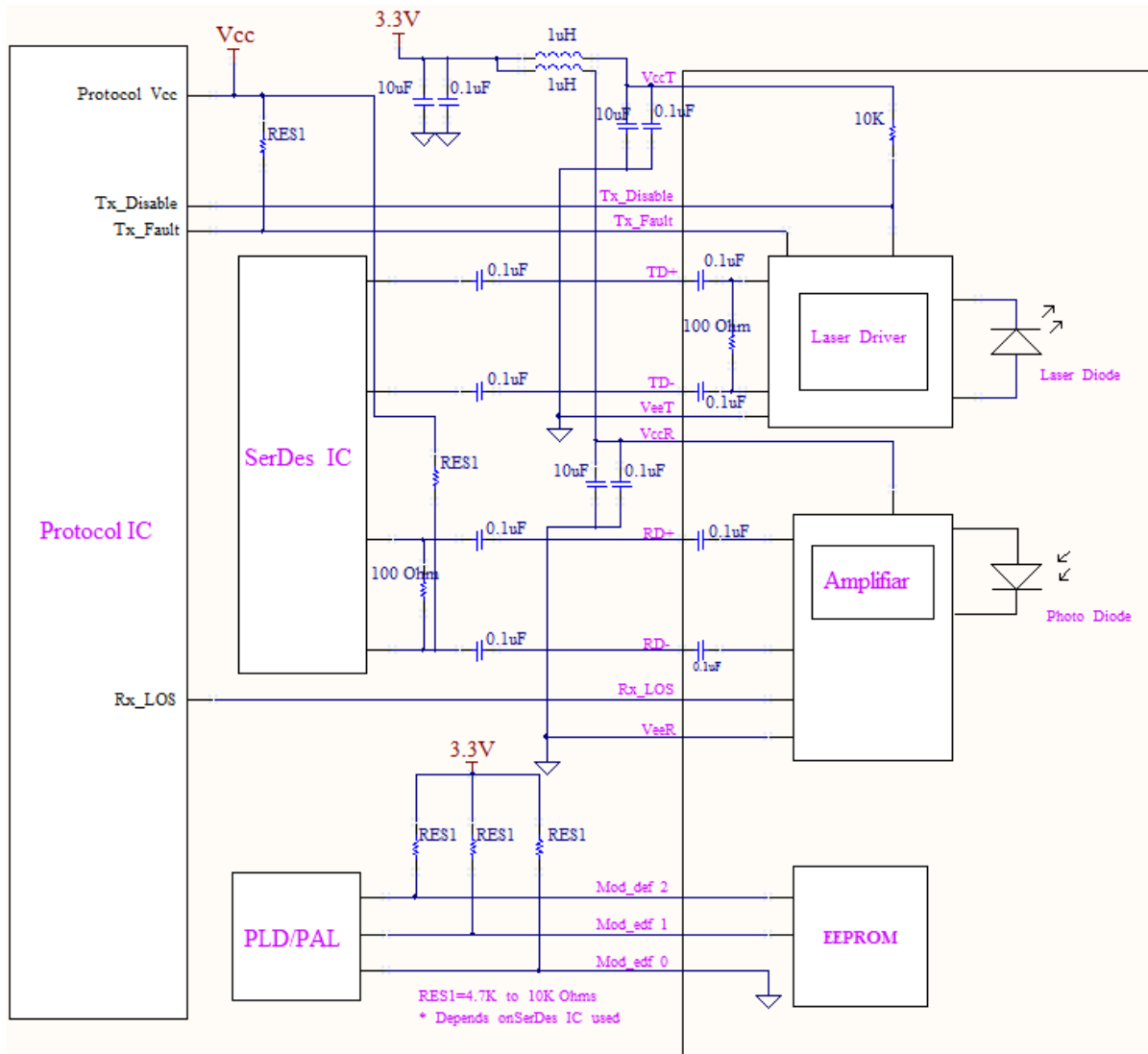

Pin Description

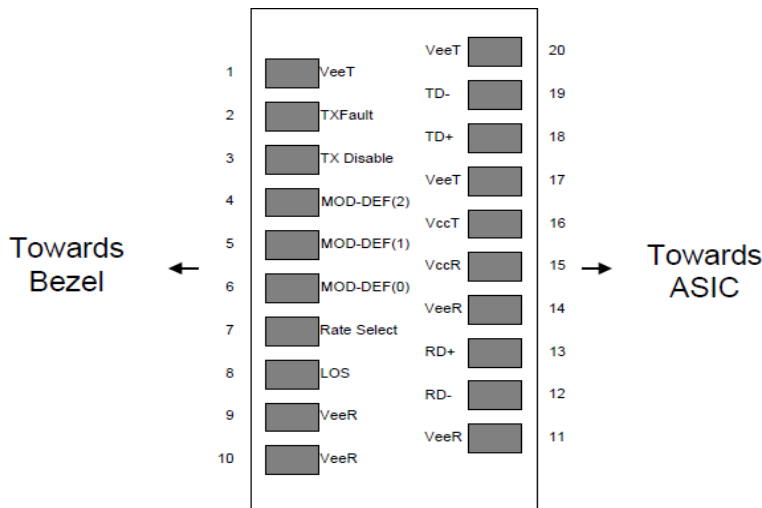

Pin out of Connector Block on Host Board

Pin Descriptions

Pin	Symbol	Name/Description	NOTE
1	V _{EET}	Transmitter Ground (Common with Receiver Ground)	1
2	T _{FAULT}	Transmitter Fault.	
3	T _{DIS}	Transmitter Disable. Laser output disabled on high or open.	2
4	MOD_DEF(2)	Module Definition 2. Data line for Serial ID.	3
5	MOD_DEF(1)	Module Definition 1. Clock line for Serial ID.	4
6	MOD_DEF(0)	Module Definition 0. Grounded within the module.	4
7	Rate Select	No connection required	4
8	LOS	Loss of Signal indication. Logic 0 indicates normal operation.	5
9	V _{EER}	Receiver Ground (Common with Transmitter Ground)	1
10	V _{EER}	Receiver Ground (Common with Transmitter Ground)	1
11	V _{EER}	Receiver Ground (Common with Transmitter Ground)	1
12	RD-	Receiver Inverted DATA out. AC Coupled	
13	RD+	Receiver Non-inverted DATA out. AC Coupled	
14	V _{EER}	Receiver Ground (Common with Transmitter Ground)	1
15	V _{CCR}	Receiver Power Supply	
16	V _{CCT}	Transmitter Power Supply	
17	V _{EET}	Transmitter Ground (Common with Receiver Ground)	1
18	TD+	Transmitter Non-Inverted DATA in. AC Coupled.	
19	TD-	Transmitter Inverted DATA in. AC Coupled.	
20	V _{EET}	Transmitter Ground (Common with Receiver Ground)	1

Notes:

1. Circuit ground is internally isolated from chassis ground.

2. TX Fault is an open drain output, which should be pulled up with 4.7 kΩ to 10 kΩ resistor on the host board. Pull up voltage between 2.0 V to $V_{CC}/R+0.3$ V. When high, output indicates a laser fault of some kind. Low indicates normal operation. In the low state, the output will be pulled to <0.8 V. When sensing an improper power level in the laser driver, the SFP sets this signal high and turns off the laser. TX-FAULT can be reset with the TX-DISABLE line. The signal is in LVTTTL level.

3. TX disable is an input that is used to shut down the transmitter optical output. It is pulled up within the module with 4.7 kΩ to 10 kΩ resistor. Its states are: Low (0 V to 0.8 V): Transmitter on; (>0.8 V, <2.0 V): Undefined; High (2.0 V to $V_{CC}/R+0.3$ V): Transmitter Disabled; Open: Transmitter Disabled. The TX-DISABLE signal is high (LVTTTL logic “1”) to turn off the laser output. The laser will turn on when TX-DISABLE is low (LVTTTL logic “0”).

4. Should be pulled up with 4.7 kΩ to 10 kΩ on host board to a voltage between 2.0 V to $V_{CC}/R+0.3$ V. MOD_DEF(0) pulls line low to indicate module is plugged in.

5. LOS (Loss of Signal) is an open collector/drain output, which should be pulled up with 4.7 kΩ to 10 kΩ resistor. Pull up voltage between 2.0 V to $V_{CC}/R+0.3$ V. When high, this output indicates the received optical power is below the worst-case receiver sensitivity (as defined by the standard in use). Low indicates normal operation. In the low state, the output will be pulled to <0.8 V.

The RX-LOS is high (LVTTTL logic “1”) when there is no incoming light from the companion transceiver. This signal is normally used by the system for the diagnostic purpose. The signal is operated in LVTTTL level.

Specifications

Absolute Maximum Ratings

Parameter	Symbol	Min.	Typ.	Max.	Unit	Note
Storage Temperature	T _S	-40		85	°C	
Storage Ambient Relative Humidity	H _A	0		85	%	
Power Supply Voltage	V _{CC}	-0.5		4	V	
Signal Input Voltage		-0.3		V _{CC} +0.3	V	
Receiver Damage Threshold		+3			dBm	
Lead Soldering Temperature/Time	T _{SOLD}			260/10	°C/sec	1
Lead Soldering Temperature/Time	T _{SOLD}			360/10	°C/sec	2

Notes:

1. Suitable for wave soldering.
2. Only for soldering by iron.

Recommended Operating Conditions

Parameter	Symbol	Min.	Typ.	Max.	Unit	Note
Case Operating Temperature	T _{case}	0		+70	°C	Commercial
		-40		+85	°C	Industrial
Ambient Humidity	H _A	5		70	%	Non-condensing
Power Supply Voltage	V _{CC}	3.13	3.3	3.47	V	

Power Supply Current	I _{cc}	280	mA	
Data Rate		1250/1250	Mbps	TX rate/RX rate
Transmission Distance		20	km	
Coupled Fiber	Single-mode fiber			9/125 μm G.652

Specification of Transmitter

Parameter	Symbol	Min.	Typ.	Max.	Unit	Note
Average Output Power	P _{OUT}	-9		-3	dBm	
Extinction Ratio	ER	9			dB	
Center Wavelength	λ _c	1260	1310	1360	nm	
Spectrum Bandwidth (RMS)	σ			3.5	nm	FP Laser
Transmitter OFF Output Power	P _{Off}			-45	dBm	
Jitter p-p	t _j			0.1	UI	1
Output Eye Mask	Compliant with IEEE802.3z (class 1 laser safety)					2

Notes:

1. Measure at 2⁷-1 NRZ PRBS pattern.
2. Transmitter eye mask definition.

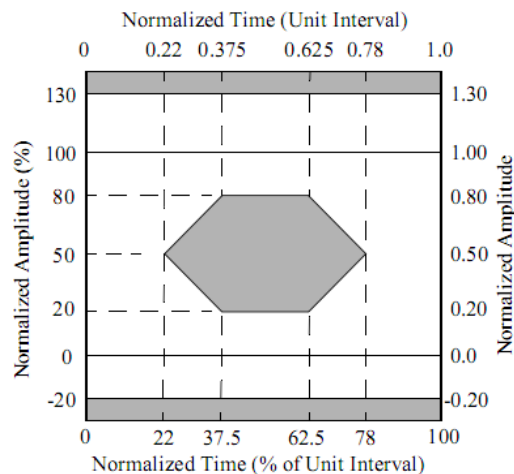

Specification of Receiver

Parameter	Symbol	Min.	Typ.	Max.	Unit	Note
Input Optical Wavelength	λ _{IN}	1270		1610	nm	
Receiver Sensitivity	P _{IN}			-24	dBm	1
Input Saturation Power (Overload)	PSAT	-3			dBm	
Loss of Signal Assert	PA	-45			dBm	
Loss of Signal De-assert	PD			-24.5	dBm	2
LOS Hysteresis	PD-PA	0.5		6	dB	

Notes:

1. Measured with light source 1310 nm, ER = 9 dB; BER ≤ 10⁻¹² @ PRBS = 2⁷-1 NRZ
2. When LOS De-asserted, the RX data± output is signal output.

Digital Diagnostic Memory Map

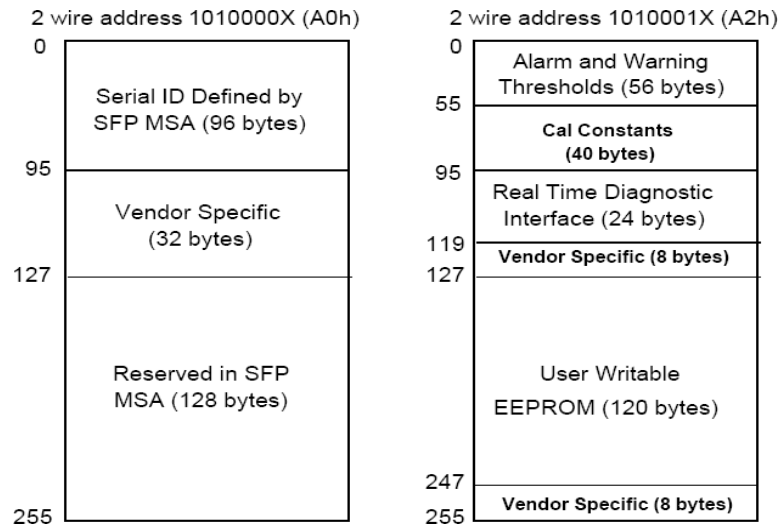

Digital Diagnostic Monitoring Information

Parameter	Unit	Accuracy
Case Temperature	°C	±3
Supply Voltage	V	±3%
Tx Bias Current	mA	±10%
Tx Optical Power	dB	±3
Rx Optical Power	dB	±3

Electrical Interface Characteristics

Parameter	Symbol	Min.	Typ.	Max.	Unit	Note
Transmitter						
Total Supply Current	I _{CC}			A	mA	1
Transmitter Disable Input-High	V _{DISH}	2		V _{CC} +0.3	V	LVTTTL
Transmitter Disable Input-Low	V _{DISL}	0		0.8	V	LVTTTL
Transmitter Fault Input-High	V _{TXFH}	2		V _{CC} +0.3	V	LVTTTL
Transmitter Fault Input-Low	V _{TXFL}	0		0.8	V	LVTTTL
Receiver						
Total Supply Current	I _{CC}			B	mA	1
LOS Output Voltage-High	V _{LOSH}	2		V _{CC} +0.3	V	LVTTTL
LOS Output Voltage-Low	V _{LOSL}	0		0.8	V	LVTTTL

Note 1: A (TX)+ B (RX) = 280 mA (Not include termination circuit)

Ordering Information

Product Name	Product Description
SFP-AG-LP-31-10	SFP Plug-in, 1.25 Gbps, 10 km, TX=1310/RX wide, on two single-mode fibers, LC/PC Blue
SFP-AG-LP-31-10A	SFP Plug-in, 1.25 Gbps, 10km, TX=1310/RX wide, on two single mode fibers, LC/PC Blue, Industrial Temp -40 °C to +85 °C
JSP-AG-LP-31-10	SFP Plug-in, 1.25 Gbps, 10 km, TX=1310/RX wide, on two single-mode fibers, LC/PC Blue, Compatible with Juniper
JSP-AG-LP-31-10A	SFP Plug-in, 1.25 Gbps, 10km, TX=1310/RX wide, on two single mode fibers, LC/PC Blue, Compatible with Juniper, Industrial Temp -40 °C to +85 °C

Contact Information



Ascent Communication Technology Ltd

AUSTRALIA

140 William Street, Melbourne
Victoria 3000, AUSTRALIA
Phone: +61-3-8691 2902

CHINA

Unit 1933, 600 Luban Road
200023, Shanghai, CHINA
Phone: +86-21-60232616

EUROPE

Pfarrer-Bensheimer-Strasse 7a
55129 Mainz, GERMANY
Phone: +49 (0) 6136 926 3246

Hong Kong SAR

Unit 9, 12th Floor, Wing Tuck Commercial Centre
177 Wing Lok Street, Sheung Wan, Hong Kong SAR
Phone: +852-2851 4722

USA

2710 Thomes Ave
Cheyenne, WY 82001, USA
Phone: +1 203 350 9822

VIETNAM

11th Floor, Hoa Binh Office Tower
106 Hoang Quoc Viet Street, Nghia Do Ward
Cau Giay District, Hanoi 10649, VIETNAM
Phone: +84-24-37955917

Specifications and product availability are subject to change without notice.

Copyright © 2024 Ascent Communication Technology Limited. All rights reserved.

Ver. ACT_SFP-AG-LP-31-10_Datasheet_V1f_Dec_2020