

100 Gb/s 40 km QSFP28 ER4 Lite Transceiver

QSFP Series

- Support line rates from **103.125 Gb/s**
- Transmission data rate up to **25.78125Gbps per channel**
- **Single +3.3V Power Supply**
- **Support Commercial and Industrial Temperature**
- **Low Power Dissipation**
- **Complies with EU Directive 2015/863/EU**



Ascent's 100G QSFP28 ER4 Lite is designed for 30km optical communication applications. This module contains 4-lane optical transmitter, 4-lane optical receiver and module management block including 2 wire serial inter-face. The optical signals are multiplexed to a single-mode fiber through an industry standard LC connector.

Ascent's 100G QSFP28 ER4 Lite Optical Transceiver offers service providers, network operators 100 Gigabit Ethernet connectivity options for data center networking, enterprise core aggregation, and service provider transport applications. It integrates receiver and transmitter path on one module.

In the transmit side, four lanes of serial data streams are recovered, retimed, and passed to four laser drivers. The laser drivers control 4-EML with center wavelength of 1296 nm, 1300nm, 1305nm and 1309 nm. The optical signals are multiplexed to a single-mode fiber through an industry standard LC connector.

In the receive side, the four lanes of optical data streams are optically de-multiplexed by the integrated optical de-multiplexer. Each data stream is recovered by a APD and trans-impedance amplifier, retimed. This module features a hot-pluggable electrical interface, low power consumption and 2-wire serial interface.

This product is designed with form factor, optical/electrical connections, and digital diagnostic interface according to the QSFP28 Multi-Source Agreement (MSA) and compliant to IEEE 802.3bm.

Key Features

- Support line rates from 103.125 Gb/s
- Transmission data rate up to 25.78125Gbps per channel
- Up to 30kmreach for G.652 SMF without FEC
- Up to 40kmreach for G.652 SMF with FEC
- LAN WDM EML laser and APD receiver
- High speed I/O electrical interface (CAUI-4)
- I2C interface with integrated Digital Diagnostic monitoring
- QSFP28 MSA package with duplex LC connector
- Single +3.3V power supply dissipation
Commercial: < 5W
Industrial: <5.5W
- Temperature Range:
Commercial: 0°C to +70°C
Industrial: -40°C to +85°C
- Complies with EU Directive 2015/863/EU

Outline Dimensions

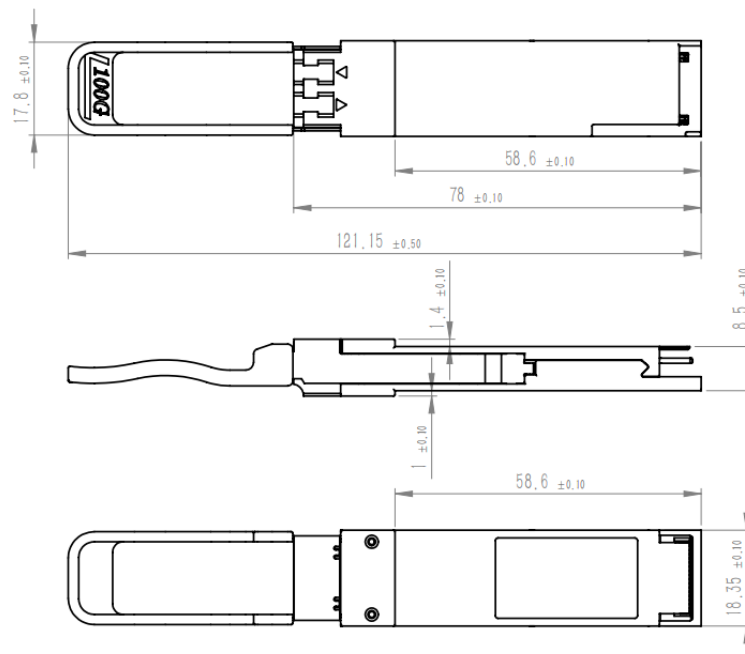

EEPROM Information

EEPROM memory map specific data field description is as below:

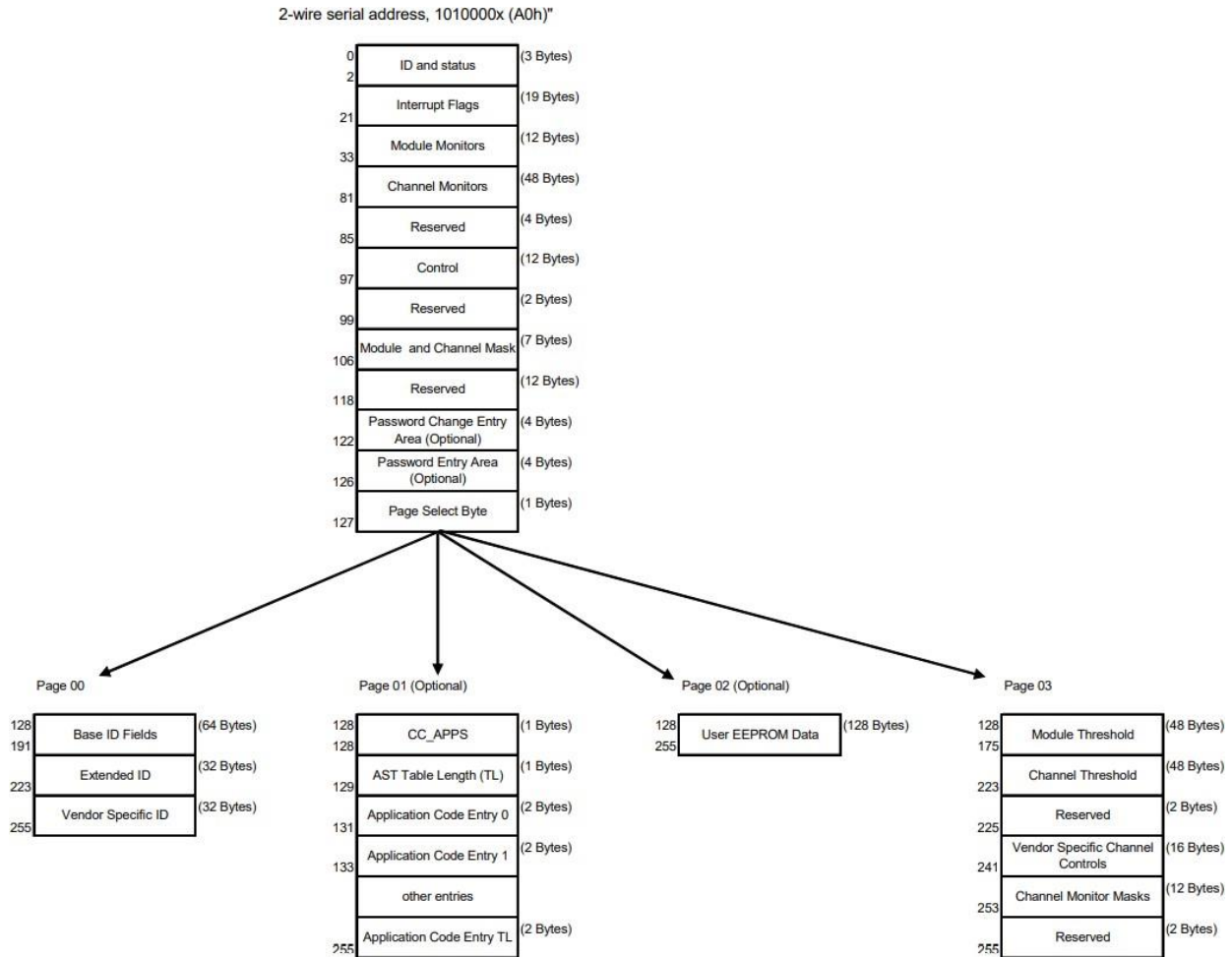

Pin Assignment

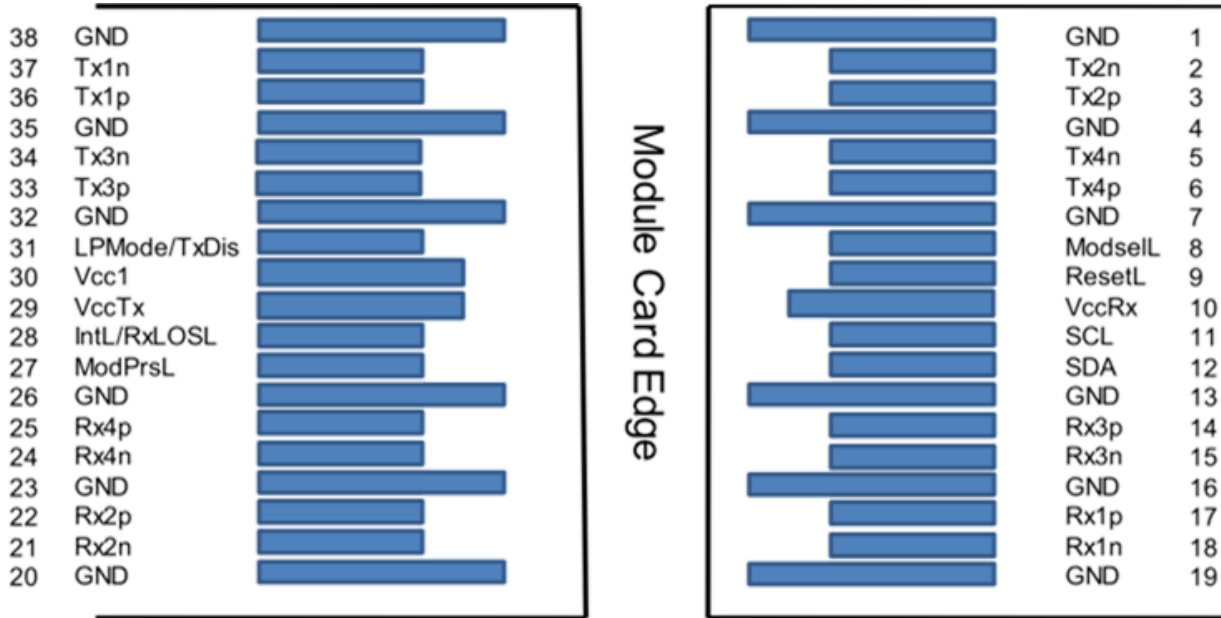

Top Side
Viewed From Top

Bottom Side
Viewed From Bottom

PIN	Logic	Symbol	Description	Plug Seq.	Notes
1		GND	Ground	1	1
2	CML-I	Tx2n	Transmitter Inverted Data Input	3	
3	CML-I	Tx2p	Transmitter Non-Inverted Data output	3	
4		GND	Ground	1	1
5	CML-I	Tx4n	Transmitter Inverted Data Input	3	
6	CML-I	Tx4p	Transmitter Non-Inverted Data output	3	
7		GND	Ground	1	1
8	LVTTLL-I	ModSelL	Module Select	3	
9	LVTTLL-I	ResetL	Module Reset	3	
10		VccRx	+ 3.3V Power Supply Receiver	2	2
11	LVCNOS-I/O	SCL	2-Wire Serial Interface Clock	3	
12	LVCNOS-I/O	SDA	2-Wire Serial Interface Data	3	
13		GND	Ground	1	
14	CML-O	Rx3p	Receiver Non-Inverted Data Output	3	
15	CML-O	Rx3n	Receiver Inverted Data Output	3	
16		GND	Ground	1	1
17	CML-O	Rx1p	Receiver Non-Inverted Data Output	3	
18	CML-O	Rx1n	Receiver Inverted Data Output	3	
19		GND	Ground	1	1
20		GND	Ground	1	1
21	CML-O	Rx2n	Receiver Inverted Data Output	3	
22	CML-O	Rx2p	Receiver Non-Inverted Data Output	3	
23		GND	Ground	1	1

24	CML-O	Rx4n	Receiver Inverted Data Output	3	1
25	CML-O	Rx4p	Receiver Non-Inverted Data Output	3	
26		GND	Ground	1	1
27	LVTTTL-O	ModPrsL	Module Present	3	
28	LVTTTL-O	IntL/Rx_LOS	Interrupt/Rx_LOS	3	
29		VccTx	+3.3 V Power Supply transmitter	2	2
30		Vcc1	+3.3 V Power Supply	2	2
31	LVTTTL-I	LPMode/TxDI S	Low Power Mode/Tx_Disable	3	
32		GND	Ground	1	1
33	CML-I	Tx3p	Transmitter Non-Inverted Data Input	3	
34	CML-I	Tx3n	Transmitter Inverted Data Output	3	
35		GND	Ground	1	1
36	CML-I	Tx1p	Transmitter Non-Inverted Data Input	3	

Notes:

1. GND is the symbol for signal and supply (power) common for the QSFP28 module. All are common within the QSFP28 module and all module voltages are referenced to this potential unless otherwise noted. Connect these directly to the host board signal-common ground plane.
2. Vcc Rx, Vcc1 and Vcc Tx are the receiver and transmitter power supplies and shall be applied concurrently. Requirements defined for the host side of the Host Edge Card Connector are listed in MSA. The connector pins are each rated for a maximum current of 500 mA.

Digital Diagnostic Functions

Parameter	Range	Unit	Accuracy	Calibration
Commercial Temperature	0 to +70	°C	±3°C	Internal / External
Industrial Temperature	-40 to +85	°C	±3°C	Internal / External
Voltage	3.0 to 3.6	V	±3%	Internal / External
Bias Current	30 to 100	mA	±10%	Internal / External
TX Power	-2.5 to 6.5	dBm	±3dB	Internal / External
RX Power	-15 to -6	dBm	±3dB	Internal / External

Note:

The transceivers provide serial ID memory contents and diagnostic information about the present operating conditions by the 2-wire serial interface (SCL, SDA). The diagnostic information with internal calibration or external calibration all are implemented, including received power monitoring, transmitted power monitoring, bias current monitoring, supply voltage monitoring and temperature monitoring.

Specifications

Absolute Maximum Ratings

Parameter	Symbol	Min.	Max.	Unit
Storage Temperature	T _s	-40	85	°C
Maximum Supply Voltage	V _{CC}	-0.5	3.6	%
Operating Relative Humidity	RH		85	V

Recommended Operating Conditions

Parameter	Symbol	Min.	Typ.	Max.	Unit	Note
Operating Case Temperature	T _{op}	0		+70	°C	QSFP28-100G-LP40
		-40		+85	°C	Q28-100G-LP40A
Power Supply Voltage	V _{CC}	3.13	3.3	3.47	V	QSFP28-100G-LP40
Power Supply Current	I _{CC}	-		1.44	A	QSFP28-100G-LP40
				1.67	A	
Maximum Power Dissipation	P _D			5	W	QSFP28-100G-LP40
				5.5		Q28-100G-LP40A
Aggregate Bit Rate	BR _{AVE}		103.125		Gb/s	
Lane Bit Rate	BR _{LANE}		25.78125		Gb/s	
Transmission Distance	T _D			30	km	
Coupled Fiber	Single-mode fiber					9/125 μm SMF

Optical Characteristics

Parameter	Symbol	Min.	Typical	Max.	Unit	Notes
Transmitter						
Signaling Speed per Lane			25.78125		Gbps	
Lane Wavelength	L0	1294.53	1295.56	1296.59	nm	
	L1	1299.02	1300.05	1301.09	nm	
	L2	1303.54	1304.58	1305.63	nm	
	L3	1308.09	1309.14	1310.19	nm	
Total Average Launch Power	PT			12.5	dBm	1
Average Launch Power per Lane, OMA, each Lane	Pavg	-2.5		6.5	dBm	1
Difference in launch power between any two lanes(Average and OMA) between any Two Lanes (OMA)	Ptx, diff	0		6.5	dBm	1
Average Output Power (Laser Turn off)	Poff			-30	dBm	
Side Mode Suppression Ratio	SMSR	30			dB	
Extinction Ratio, 100GE	ER	4.5			dB	
RIN20OMA	RIN			-130	dB/Hz	
Optical Return Loss Tolerance	TOL			20	dB	
Transmitter Reflectance	RT			-12	dB	
Optical Eye Mask	{0.25,0.4, 0.45, 0.25, 0.28, 0.4}				%	2
Receiver						
Signaling Rate, Each Lane			25.78125		Gbps	
Center Wavelength Lane 0	λ0	1294.53	1295.56	1296.59	nm	
Center Wavelength Lane 1	λ1	1299.02	1300.05	1301.09	nm	

Center Wavelength Lane 2	$\lambda 2$	1303.54	1304.58	1305.63	nm	
Center Wavelength Lane 3	$\lambda 3$	1308.09	1309.14	1310.19	nm	
Damage threshold , Each Lane	Pdamage	-6			dBm	
Average Receive Power, Each Lane		-20.5		-7	dBm	
Receiver Sensitivity(OMA) Each Lane (100GbE) (BER = 1x10 ⁻¹²)	SEN			-15	dBm	3
Receiver Sensitivity(OMA), Each Lane (100GbE) (BER = 5x10 ⁻⁵)	SEN			-18.5	dBm	4
Los Assert	LosA	-35			dBm	
Los De-assert	LosDA			-18	dBm	
Los Hysteresis	LosH	0.5			dB	

Note:

1. The optical power is launched into SMF.
2. Measured with a PRBS 231-1 test pattern @25.78125, Hit ratio≤5E-5.
3. Measured with a PRBS 231-1 test pattern @25.78125 Gb/s, BER≤1E-12.
4. Measured with a PRBS 231-1 test pattern @25.78125 Gb/s, BER≤5E-5.

Electrical Characteristics

High-Speed Signal: Compliant to CAUI-4 (IEEE 802.3bm)

Low-Speed Signal: Compliant to SFF-8679

Parameter	Symbol	Min	Typ	Max	Unit	Notes
Transmitter (Module Input)						
Data Rate, Each Lane			25.78125		Gbps	
Differential Voltage pk-pk	Vpp			900	mV	1
Common Mode Voltage	Vcm	-350		2850	mV	
Transition Time	Trise/Tf all	10			ps	2
Receiver (Module Output)						
Data Rate, Each Lane			25.78125		Gbps	
Common Mode Noise, RMS	Vrms			17.5	mV	
Differential Output Voltage Swing	Vout, pp			900	mV	
Eye Width	EW15	0.57			UI	
Eye Height	EH15	228			mV	
Differential Termination Resistance Mismatch				10	%	1
Transition Time	Trise/Tf all	12			ps	

Note:

1. At 1 MHz
2. 20% to 80%.

Ordering Information

Product Name	Product Description
QSFP28-100G-LP40	QSFP28 Plug-in, compatible with QSFP-100G-ER4L-S (with FEC), 40 km Optical Transceiver, Duplex LC, DOM
QSFP28-100G-L40A	QSFP28 Plug-in, 100G-ER4L, 40km (with FEC) 1310nm Optical Transceiver, LC, DOM, -40 to 85°C
JQ28-100G-LP40	QSFP28 Plug-in, compatible with QSFP-100G-ER4L-S (with FEC), 40 km Optical Transceiver, Duplex LC, DOM, Compatible with Juniper
JQ28-100G-LP40A	QSFP28 Plug-in, 100G-ER4L, 40km (with FEC) 1310nm Optical Transceiver, LC, DOM, Industrial Temp -40 °C to +85 °C, Compatible with Juniper

Contact Information



Ascent Communication Technology Ltd

AUSTRALIA

140 William Street, Melbourne
Victoria 3000, AUSTRALIA
Phone: +61-3-8691 2902

CHINA

Unit 1933, 600 Luban Road
200023, Shanghai, CHINA
Phone: +86-21-60232616

EUROPE

Pfarrer-Bensheimer-Strasse 7a
55129 Mainz, GERMANY
Phone: +49 (0) 6136 926 3246

Hong Kong SAR

Unit 9, 12th Floor, Wing Tuck Commercial Centre
177 Wing Lok Street, Sheung Wan, Hong Kong SAR
Phone: +852-2851 4722

USA

2710 Thomes Ave
Cheyenne, WY 82001, USA
Phone: +1 203 350 9822

VIETNAM

11th Floor, Hoa Binh Office Tower
106 Hoang Quoc Viet Street, Nghia Do Ward
Cau Giay District, Hanoi 10649, VIETNAM
Phone: +84-24-37955917

WEB: www.ascentcomtec.com

EMAIL: sales@ascentcomtec.com

Specifications and product availability are subject to change without notice.

Copyright © 2024 Ascent Communication Technology Limited. All rights reserved.

Ver. ACT_QSFP28-100G-LP40_Datasheet_V1f_May_2019